

## SPECIFICATIONS

BORE	30.4mm
STROKE	25.8mm
DISPLACEMENT	18.73cc
WEIGHT	730g
RPM	2,000 ~ 13,000

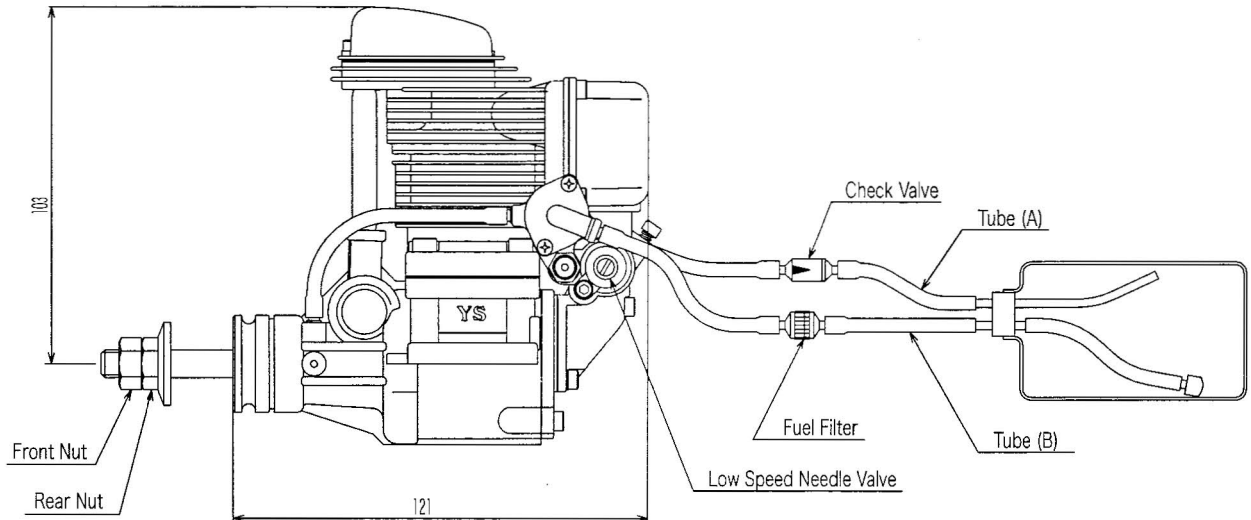

FIG.1